

Routout CNC 25 Way D Breakout Data Sheet Version 2.1

The Routout CNC 25 Way D Breakout has many uses including for CNC retrofitting / robot control. It allows you to wire to the parallel port / LPT port using screw terminals, this makes wiring limit / sensing switches to you CNC machine a breeze.

Features:

- All connected printer I/O lines have screw terminal connector.
- Very easy to wire limit / control switches.

Wiring diagram for use with Routout CNC.

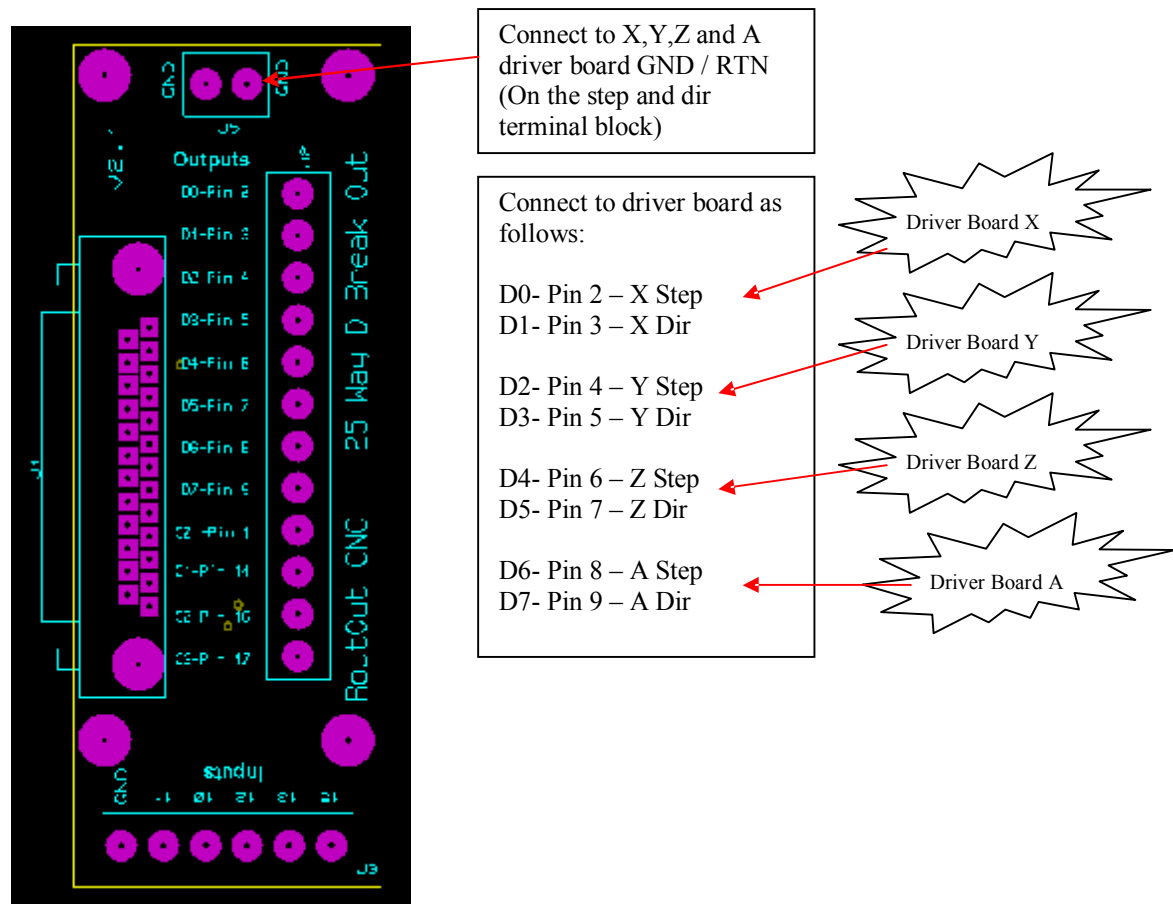

Absolute Maximum Ratings

Δ Exceeding these ratings WILL destroy you're your PC or the printer port / interface card, You have been warned !

Δ Maximum 5V input on the Input port.

Contact:

RoutOut CNC LTD
Unit D5
Capel Hendre Industrial Estate,
Ammanford
SA18 3SJ

Phone (01269) 844744 www.routoutcnc.com